



Network Interface Card Smart Regulator

MAX1810

General Description

The MAX1810 powers peripheral component interconnect (PCI) Ethernet network interface cards (NICs), modem cards, and other devices that utilize both the main and auxiliary (standby) voltages supplied by PCI-compliant systems. The device generates an uninterrupted +3.3V at up to 500mA from either a +5V main or a +5V standby supply. When both +5V inputs fall below +4.1V, an internal switch connects the +3.3V auxiliary input to the output.

An auxiliary switch resistance of only 0.18Ω minimizes output droop from the +3.3V auxiliary supply. In addition, the MAX1810 guarantees that no reverse current flows from the output to any unbiased or inactive input, and remains stable with as little as 1μF of output bypass capacitance at its output.

The MAX1810 is available in a compact 8-pin high-power (0.9W) SO package.

Applications

- PCI Adapter Cards
- Network Interface Cards
- Modem Cards

Features

- ◆ Uninterrupted +3.3V Output
- ◆ Up to 500mA Output Current
- ◆ High-Power 0.9W SO-8 Package
- ◆ Thermal and Overcurrent Protection
- ◆ Only 1μF Output Capacitor
- ◆ Internal 0.18Ω +3.3V Auxiliary Switch
- ◆ No Reverse Current to Inactive Inputs

Ordering Information

PART	TEMP. RANGE	PIN-PACKAGE
MAX1810ESA	-40°C to +85°C	8 SO

Typical Operating Circuit

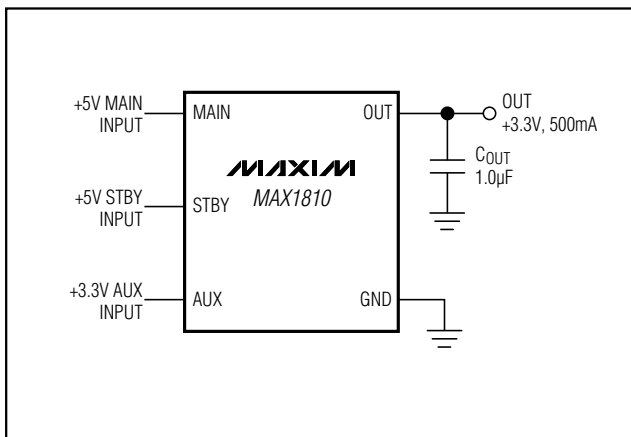

Pin Configuration

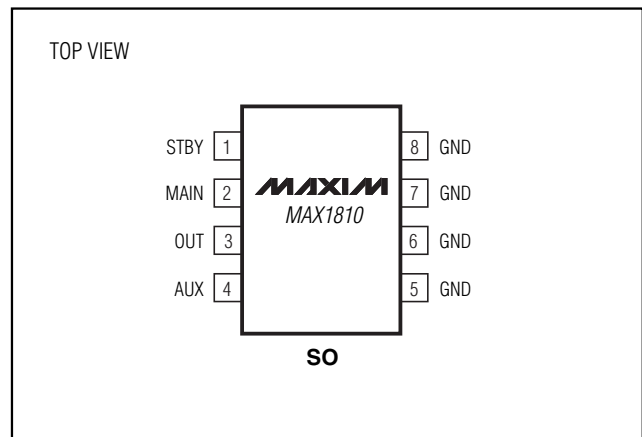

Network Interface Card Smart Regulator

ABSOLUTE MAXIMUM RATINGS

MAIN, STBY, AUX, OUT to GND-0.3V to +6.0V
 OUT to AUX-0.3V to +6.0V
 OUT Maximum Output Current1750mA
 Continuous Power Dissipation ($T_A = +70^\circ\text{C}$)
 8-Pin SO (derate 11.75mW/ $^\circ\text{C}$ above $+70^\circ\text{C}$).....900mW

Operating Temperature Range-40 $^\circ\text{C}$ to +85 $^\circ\text{C}$
 Junction Temperature+150 $^\circ\text{C}$
 Storage Temperature Range-65 $^\circ\text{C}$ to +150 $^\circ\text{C}$
 Lead Temperature (soldering, 10s)+300 $^\circ\text{C}$

Stresses beyond those listed under "Absolute Maximum Ratings" may cause permanent damage to the device. These are stress ratings only, and functional operation of the device at these or any other conditions beyond those indicated in the operational sections of the specifications is not implied. Exposure to absolute maximum rating conditions for extended periods may affect device reliability.

ELECTRICAL CHARACTERISTICS

($V_{\text{MAIN}} = V_{\text{STBY}} = +5.0\text{V}$, $V_{\text{AUX}} = +3.3\text{V}$, $T_A = 0^\circ\text{C}$ to $+85^\circ\text{C}$, unless otherwise noted. Typical values are at $T_A = +25^\circ\text{C}$.)

PARAMETER	CONDITIONS	MIN	TYP	MAX	UNITS
MAIN or STBY Input Range		4.5		5.5	V
AUX Input Range		3.0		3.6	V
Maximum Load Current		500			mA
MAIN or STBY Quiescent Current	$I_{\text{OUT}} = 10\text{mA}$		0.75	3	mA
AUX Quiescent Current	$V_{\text{MAIN}} = V_{\text{STBY}} = 0$, $V_{\text{AUX}} = +3.6\text{V}$		0.2	0.5	mA
Reverse Leakage from AUX to MAIN or STBY	$V_{\text{AUX}} = +3.6\text{V}$, V_{MAIN} or $V_{\text{STBY}} = 0$		1	20	μA
Reverse Leakage from MAIN or STBY to AUX	$V_{\text{AUX}} = 0$, V_{MAIN} or $V_{\text{STBY}} = +5.5\text{V}$		1	100	μA
OUT Load Capacitance	$C_{\text{OUT}} \text{ ESR} < 50\text{m}\Omega$		1		μF
MAIN or STBY Detect Threshold	MAIN or STBY falling	3.925	4.100	4.275	V
MAIN or STBY High Threshold	MAIN or STBY rising			4.475	V
MAIN or STBY Hysteresis			150		mV
OUT Voltage	$+4.5\text{V} < (V_{\text{MAIN}} \text{ or } V_{\text{STBY}}) < +5.5\text{V}$, $0 < I_{\text{OUT}} < 400\text{mA}$	3.234	3.3	3.366	V
OUT Line Regulation	$+4.5\text{V} < (V_{\text{MAIN}} \text{ or } V_{\text{STBY}}) < +5.5\text{V}$		0.01		%
OUT Load Regulation	$I_{\text{OUT}} = 30\text{mA}$ to 400mA , V_{MAIN} or $V_{\text{STBY}} = +5\text{V}$		0.22		%
AUX to OUT Voltage Drop	$I_{\text{OUT}} = 400\text{mA}$		72	118	mV
AUX Switch Resistance	MAIN = STBY = GND		0.180	0.295	Ω
AUX Disable Threshold		2.5		2.8	V
Thermal Shutdown			170		$^\circ\text{C}$
Thermal Shutdown Hysteresis			20		$^\circ\text{C}$
Current-Limit Threshold	$V_{\text{AUX}} = V_{\text{OUT}} = 0$	520	900	1750	mA

Network Interface Card Smart Regulator

MAX1810

ELECTRICAL CHARACTERISTICS

($V_{MAIN} = V_{STBY} = +5.0V$, $V_{AUX} = +3.3V$, $T_A = -40^{\circ}C$ to $+85^{\circ}C$, unless otherwise noted.) (Note 1)

PARAMETER	CONDITIONS	MIN	MAX	UNITS
MAIN or STBY Input Range		4.5	5.5	V
AUX Input Range		3.0	3.6	V
Maximum Load Current		500		mA
MAIN or STBY Quiescent Current	$I_{OUT} = 10mA$		3	mA
AUX Quiescent Current	$V_{MAIN} = V_{STBY} = 0$, $V_{AUX} = +3.6V$		0.5	mA
Reverse Leakage from AUX to MAIN or STBY	$V_{AUX} = +3.6V$, V_{MAIN} or $V_{STBY} = 0$		20	μA
Reverse Leakage from MAIN or STBY to AUX	$V_{AUX} = 0$, V_{MAIN} or $V_{STBY} = +5.5V$		100	μA
MAIN or STBY Detect Threshold	MAIN or STBY falling	3.925	4.275	V
MAIN or STBY High Threshold	MAIN or STBY rising		4.475	V
OUT Voltage	$+4.5V < (V_{MAIN}$ or $V_{STBY}) < +5.5V$, $0 < I_{OUT} < 400mA$	3.234	3.366	V
AUX to OUT Voltage Drop	$I_{OUT} = 400mA$		118	mV
AUX Switch Resistance	MAIN = STBY = GND		0.295	Ω
AUX Disable Threshold		2.5	2.8	V
Current-Limit Threshold	$V_{AUX} = V_{OUT} = 0$	520	1750	mA

Note 1: Specifications to $-40^{\circ}C$ are guaranteed by design, not production tested.

Typical Operating Characteristics

(V_{MAIN} , $V_{STBY} = +5V$, $V_{AUX} = +3.3V$, $C_{OUT} = 1\mu F$, $T_A = +25^{\circ}C$ unless otherwise noted.)

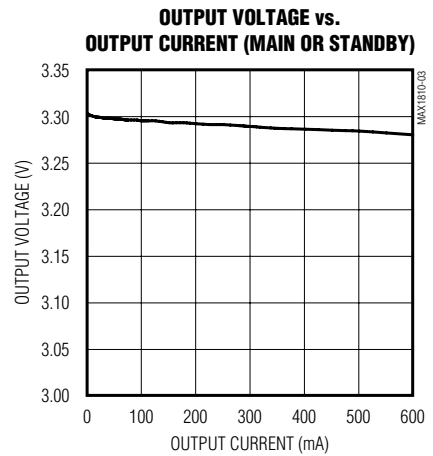
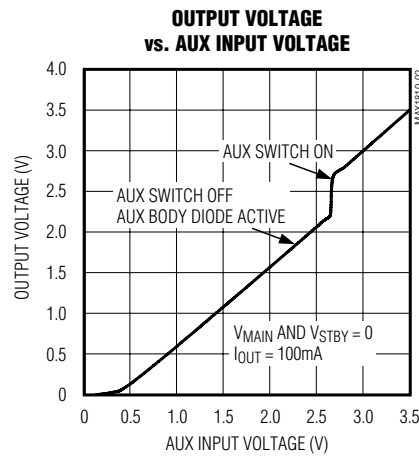
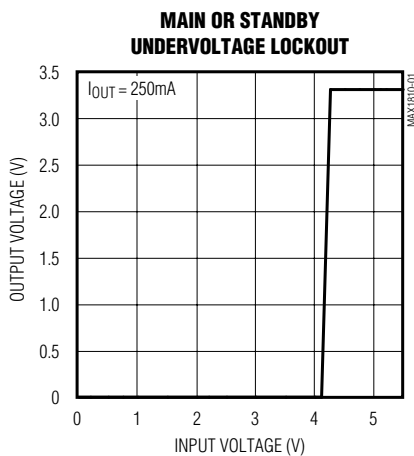

Network Interface Card Smart Regulator

Typical Operating Characteristics (continued)

(V_{MAIN} , V_{STBY} = +5V, V_{AUX} = +3.3V, C_{OUT} = 1 μ F, T_A = +25°C unless otherwise noted.)

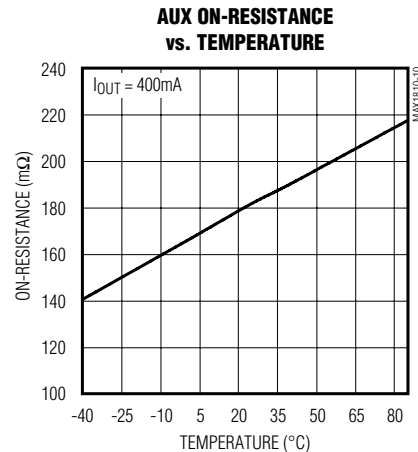
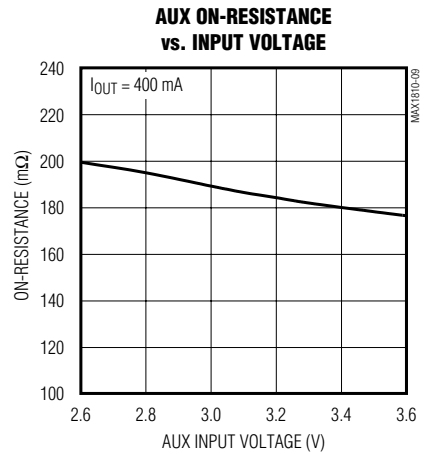
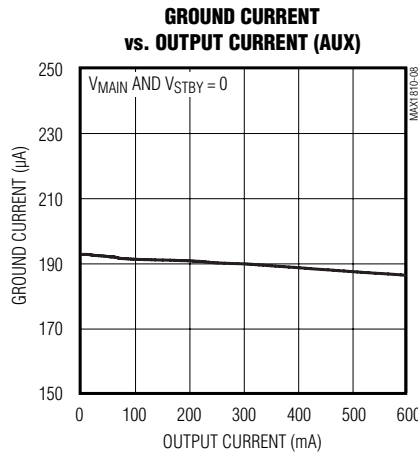
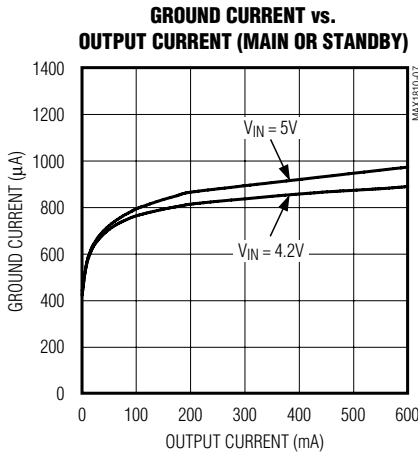
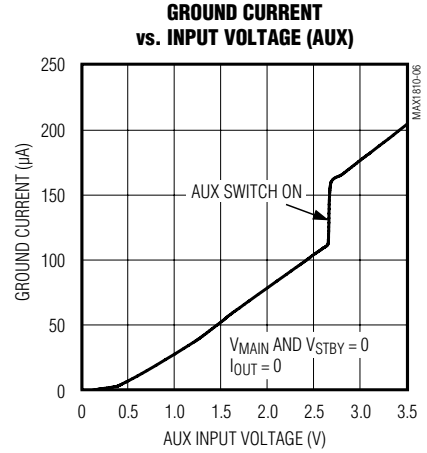
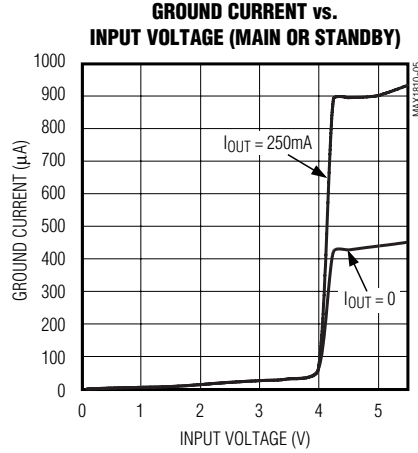
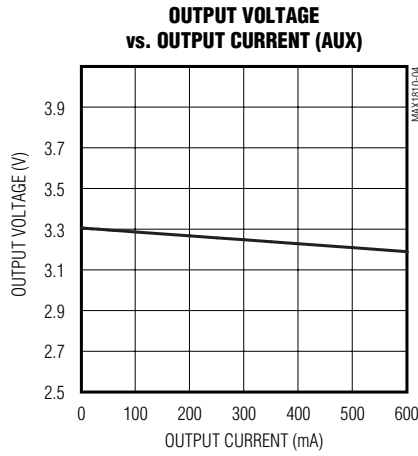

Network Interface Card Smart Regulator

MAX1810

Typical Operating Characteristics (continued)

(V_{MAIN} , V_{STBY} = +5V, V_{AUX} = +3.3V, C_{OUT} = 1 μ F, T_A = +25°C unless otherwise noted.)

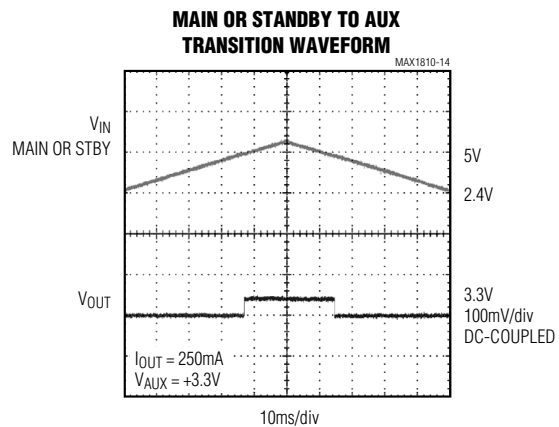
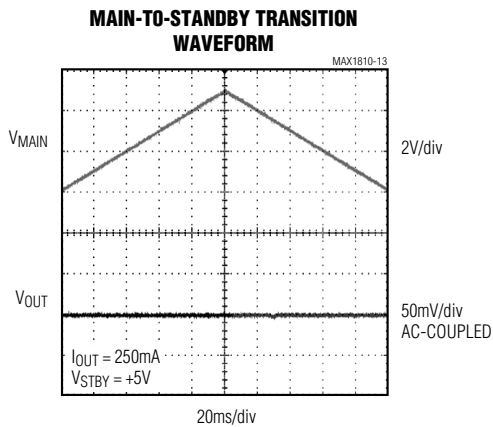
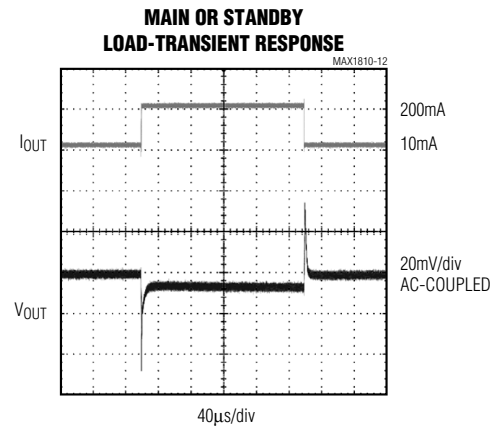
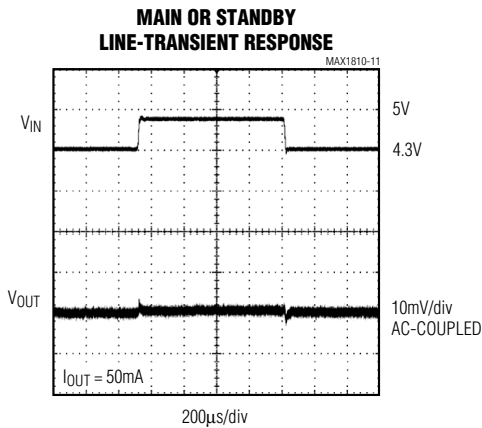

Pin Description

PIN	NAME	FUNCTION
1	STBY	+5V Standby Input
2	MAIN	+5V Main Input
3	OUT	+3.3V Output. Bypass with a 1 μ F capacitor to GND.
4	AUX	+3.3V Auxilliary Input
5-8	GND	Ground. Must connect pins 5 through 8 together to ground plane for power dissipation.

Network Interface Card Smart Regulator

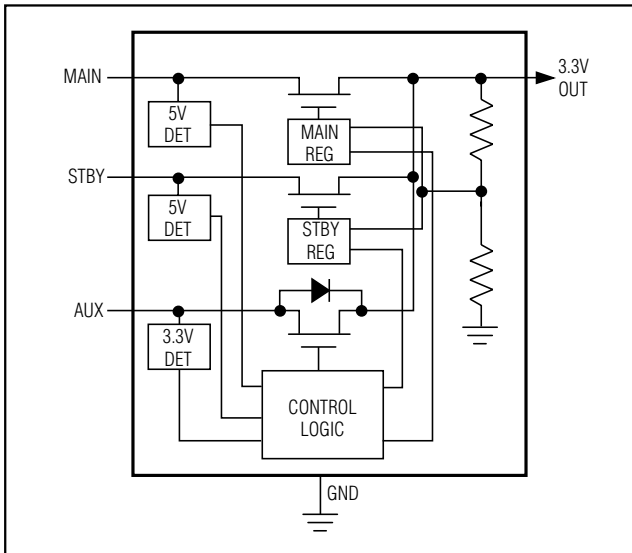

Figure 1. Functional Diagram

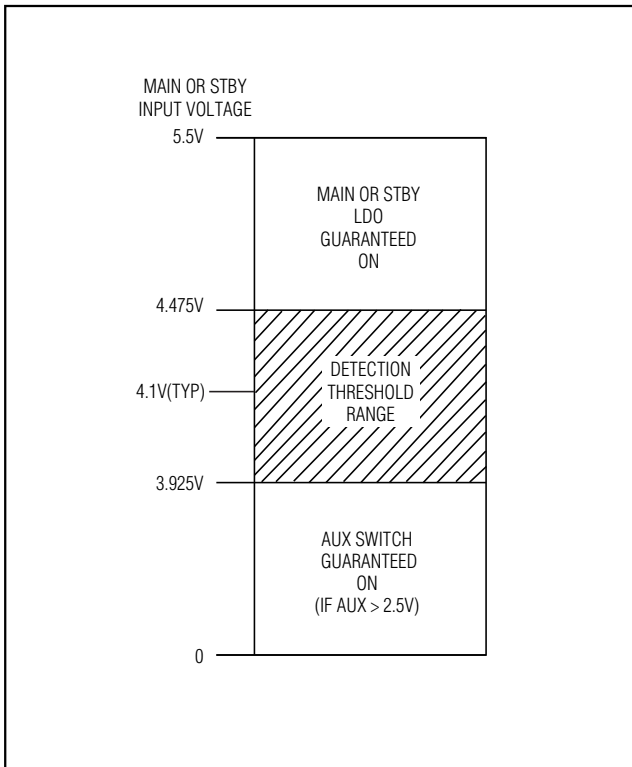

Figure 2. MAIN, STBY, and AUX Transition Voltages

Detailed Description

The MAX1810 powers NICs, modem cards, or other devices that utilize both the main and auxiliary power supplies in a PCI-compliant system, or other systems that utilize a standby or sleep-mode power bus. The MAX1810 supplies a 3.3V, 500mA output from one of three inputs: a +5V main, a +5V standby, and a +3.3V auxiliary voltage.

Each input is separately monitored (Figure 1). During normal operation, the MAIN input powers the fixed +3.3V output (OUT) through an internal linear regulator. When MAIN falls below +4.1V or is disconnected, STBY input powers the output through an internal linear regulator. When the STBY voltage is below +4.1V, an internal switch connects the +3.3V AUX input to OUT. The AUX input maintains the output until AUX falls below +2.5V. Figure 2 shows MAX1810 input transition thresholds. Switchover from one input to another is fast enough to prevent OUT from falling below +3V under all cases unless all inputs are below their required voltages. If both MAIN and STBY are above +4.475V, the MAIN input supplies the output.

The MAX1810 prevents reverse current from flowing from the output to any unbiased or low-voltage input.

Linear Regulators

The MAIN or STBY inputs generate the +3.3V output through linear regulators. Each regulator uses an internal P-channel MOSFET pass transistor. The MAIN or STBY linear regulator will operate until its input falls below +4.1V, when it shuts off. Either remaining regulator or AUX input then powers the output. MAIN takes precedence when both MAIN and STBY are valid.

+3.3V AUX Switch

A 0.18 Ω internal switch connects the AUX input to the output when both MAIN and STBY are below 4.1V and AUX is greater than 2.5V. When both MAIN and STBY are below 4.1V or unconnected, and AUX is below 2.5V, the internal switch does not activate and OUT follows AUX less one diode drop.

Thermal and Overcurrent Protection

Thermal overload protection limits total power dissipation in the MAX1810. When the junction temperature exceeds $T_J = +170^\circ\text{C}$, the MAX1810 turns off. The device turns back on once its junction temperature drops by approximately $+20^\circ\text{C}$. A continuous short at OUT will result in a pulsed output as the thermal overload circuitry cycles the device on and off.

Network Interface Card Smart Regulator

MAX1810

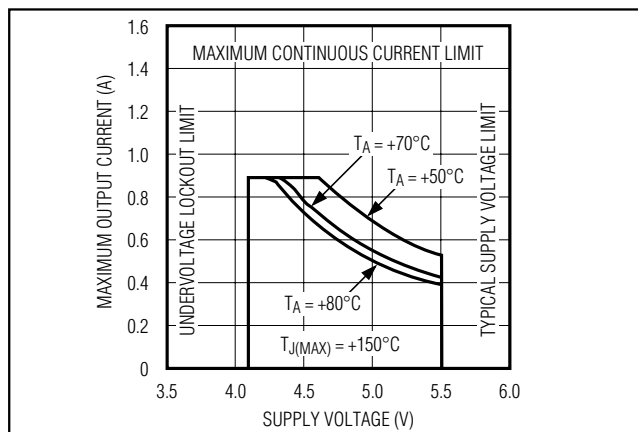

Figure 3. Power Operating Region: Maximum Output Current vs. Supply Voltage

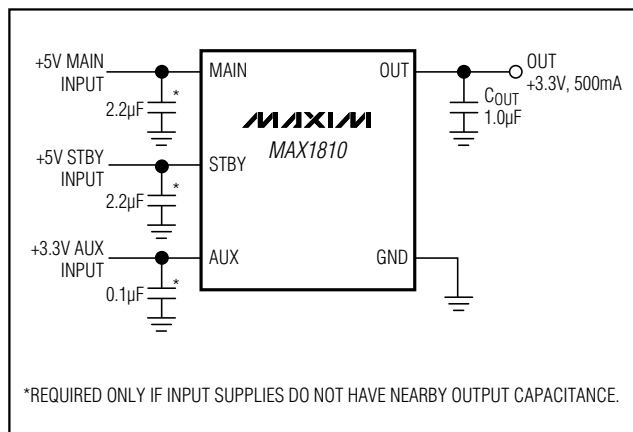

Figure 4. Typical Application Circuit

Thermal overload protection safeguards the MAX1810 in the event of fault conditions. For continuous operation, do not exceed the absolute maximum junction-temperature rating of $T_J = +150^\circ\text{C}$.

Both the MAIN and STBY regulators also feature over-current protection nominally at 900mA. The AUX switch is not current limited.

Operating Region and Power Dissipation

Maximum power dissipation of the MAX1810 depends on the thermal resistance of the case and circuit board, the temperature difference between the die junction and ambient air, and the rate of airflow. The power dissipation of the device is $P = I_{\text{OUT}} (V_{\text{IN}} - V_{\text{OUT}})$. The resulting maximum power dissipation is:

$$P_{\text{MAX}} = ((T_{\text{J(MAX)}} - T_{\text{A}}) / (\theta_{\text{JC}} + \theta_{\text{CA}}))$$

where $T_{\text{J(MAX)}}$ is the maximum junction temperature (150°C) and T_{A} is the ambient temperature, θ_{JC} is the thermal resistance from the die junction to the package case, and θ_{CA} is the thermal resistance from the case through the PC board, copper traces, and other materials to the surrounding air (Figure 3). For optimum power dissipation, use a large ground plane with good thermal contact to pins 5 through 8. For multilayer boards, multiple vias are recommended.

Applications Information

Capacitor Selection

The MAX1810 requires a $1\mu\text{F}$ ceramic bypass capacitor at OUT to maintain regulator stability (Figure 4).

When switching between input supplies, the MAX1810 may cause a voltage disturbance on either the MAIN or STBY input. Limit this disturbance to below the hysteresis level (150mV) to guarantee precise switchover. If the MAIN and STBY input supplies do not have filter capacitance of their own near the MAX1810 inputs, then bypass capacitors ($2.2\mu\text{F}$ is recommended) may be needed at MAIN and STBY. If the input supplies to MAIN and STBY already have greater than $2.2\mu\text{F}$ of output capacitance, then no additional capacitance is required. Place input and output filter capacitors as close to the device as possible to minimize the effect of lead inductance of the PC board traces.

Chip Information

TRANSISTOR COUNT: 811

PROCESS: BiCMOS

Network Interface Card Smart Regulator

Package Information

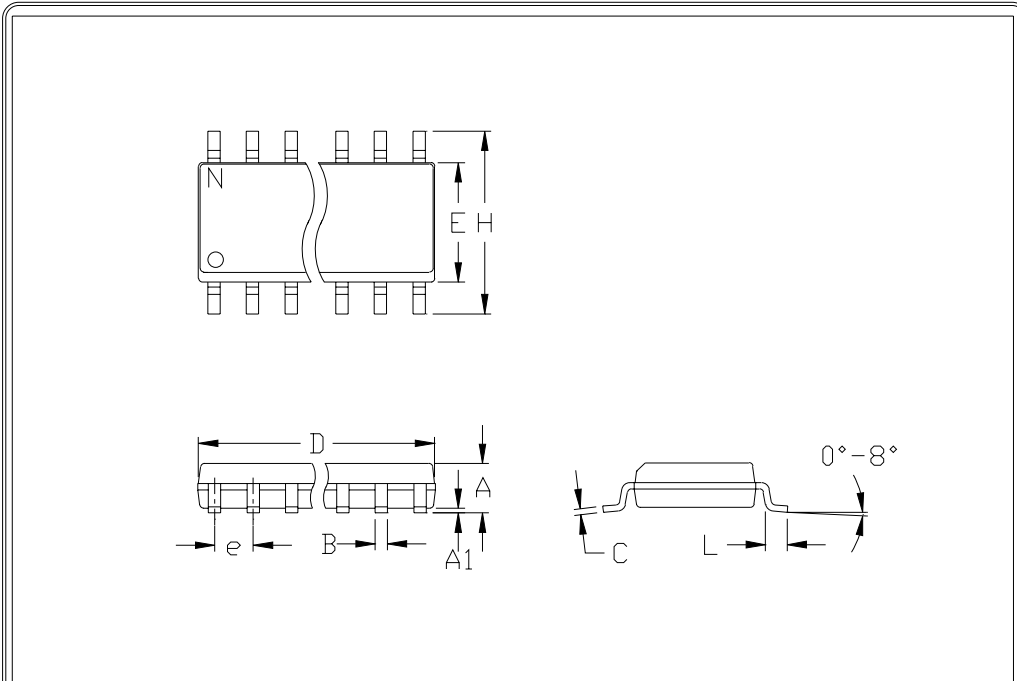

	INCHES		MILLIMETERS	
	MIN	MAX	MIN	MAX
A	0.053	0.069	1.35	1.75
A1	0.004	0.010	0.10	0.25
B	0.014	0.019	0.35	0.49
C	0.007	0.010	0.19	0.25
e	0.050		1.27	
E	0.150	0.157	3.80	4.00
H	0.228	0.244	5.80	6.20
h	0.010	0.020	0.25	0.50
L	0.016	0.050	0.40	1.27

	INCHES		MILLIMETERS		N	MS012
	MIN	MAX	MIN	MAX		
D	0.189	0.197	4.80	5.00	8	A
D	0.337	0.344	8.55	8.75	14	B
D	0.386	0.394	9.80	10.00	16	C

- NOTES:
1. D&E DO NOT INCLUDE MOLD FLASH
 2. MOLD FLASH OR PROTRUSIONS NOT TO EXCEED .15mm (.006")
 3. LEADS TO BE COPLANAR WITHIN .102mm (.004")
 4. CONTROLLING DIMENSION: MILLIMETER
 5. MEETS JEDEC MS012-XX AS SHOWN IN ABOVE TABLE
 6. N = NUMBER OF PINS

 <small>120 SAN GABRIEL DR. SUNNYVALE CA 94086 FAX (408) 737 7154</small> <small>PROPRIETARY INFORMATION</small>	PACKAGE FAMILY OUTLINE: SOIC .150"		21-0041 A
	TITLE		DOCUMENT CONTROL NUMBER

Maxim cannot assume responsibility for use of any circuitry other than circuitry entirely embodied in a Maxim product. No circuit patent licenses are implied. Maxim reserves the right to change the circuitry and specifications without notice at any time.

8 _____ **Maxim Integrated Products, 120 San Gabriel Drive, Sunnyvale, CA 94086 408-737-7600**